

DAYTONA®

Installing Instruction

1. How to connect wiring leads

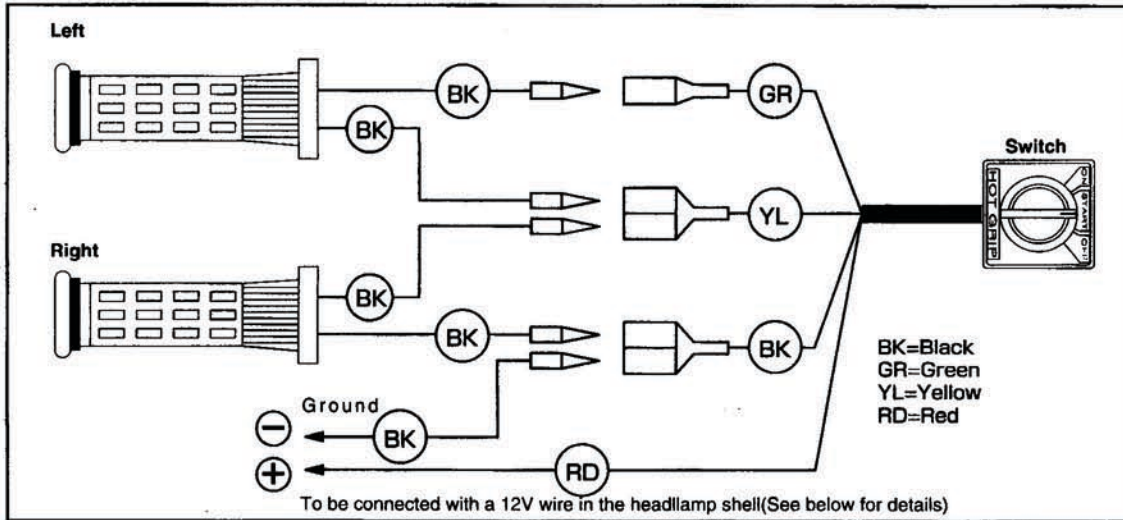

Note : ATV Grip Set comes with the same grips between the right and the left.

The black and the red wiring leads coming out of the switch should be connected as follows ;

Switch	Yamaha	Honda	Suzuki	Kawasaki
The Red ⇒	The Brown	The Black	The Orange	The Brown
The black ⇒	The Black	The Green	The Black/White	The Black/Yellow

How to use the supplied connector

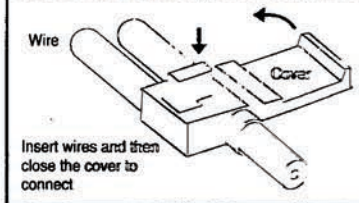

2. How to fix the switch

A) When fixed on a handlebar

Fix the supplied handlebar clamp on a handlebar.
And then tape the switch on the handlebar clamp using the supplied adhesive

B) Other cases

Tape the switch on any place you want using the supplied adhesive

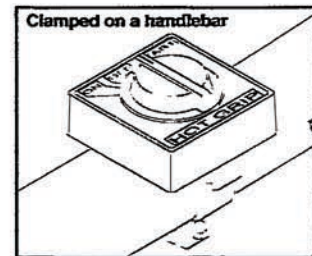

3. How to fix the grips

Must-use an exclusive glue for grips or a glue of mixing two chemicals, when inserted to a handlebar.

Otherwise the grip may come off from the handlebar or the heating wire inside may be broken.

Must not use a sort of instant-stiff type glue.

4. Operations

A) Must not use when engine stopping but only when engine running

B) "Start" position of the switch must be used only when starting heat, and after one minute must shift to "On" position

C) Never use "Start" position while riding, but only "On" or "Off" position.

Otherwise, this grip may be broken.

D) Can be used for 12V motorcycles

Wattage

Switch	Wattage
ON	12V14.4W
START	12V57.6W